

2.2 Mounting Process

- Cut out rectangle holes on the panel for installing the controller according to the required hole size. When installing more than one controller, the minimum horizontal and vertical distance between two holes should be 25mm and 30mm respectively.
- Insert the controller into the hole on the panel.
- Insert mounting bracket in the slot for mounting the controller.
- Push the mounting bracket tightly to connect the instrument and the panel firmly.

Accessories:

- Two mounting bracket
- Operation Manual (also available on our website)

2.3 Panel layout

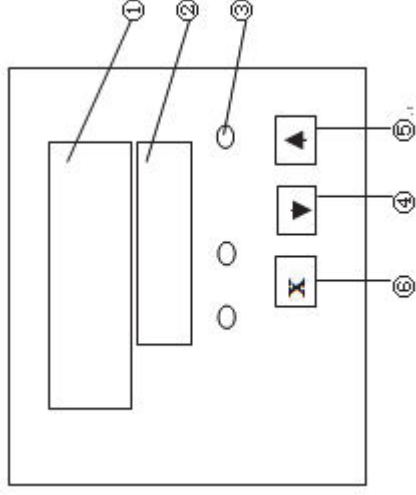

- PV Display device (Red)
- Display the measuring temperature or according to the instrument's state to display the various types of prompt code.
- SV Display device (Green)
- Display the set temperature or according to the instrument's state to display the various type of parameters as the timing time and etc.
- Indicator
- RUN indicator for auto-tuning (Green), Twinkling at working.
- OUT indicator for heating output (Green), Bright at working.
- TIME indicator for timing (Red), Bright at work
- Digital Adjustment Key
- Used to modify the setting value and the control parameters, or for entering in the timing state.
- Function key
- Used to modify the setting value, calling out, modify and confirm the parameters.

2.4 Key Performance

- Measurement accuracy: 0.5%±1dig 2) Power: 220VAC 3)Operation Temperature:0 ~ 50°C 4)Fuzzy PID control
- This product conforms with the "Q/SQG01-1999 Intelligent Digital Display Adjustor" Standard Regulation.

III. Wiring

3.1 Attention to the wiring

- For thermocouple input, the corresponding compensation line should be used.
- Input signal lines should be far away from power supply and load lines to avoid noise interference.

3.2 Wiring Terminal's configuration

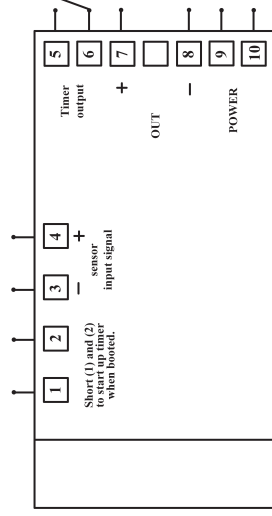

Wiring of the NTTE-2000-T/F

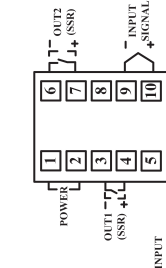

Wiring of the NTTG-2000
(Note: For NTTG-2000, Short [5] And [8] are to start timer when boot up.)

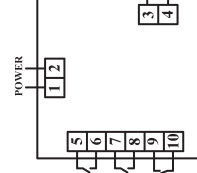

Wiring of the NTTTE-2000

I. Confirmation of the product

Please confirm the product you received is in full agreement with the model that you selected according to the following codes:

NTT □-□□□□□□□□□□-□□
① ② ③ ④ ⑤ ⑥ ⑦ ⑧ ⑨

- Panel size (mm)
D: 96×96 E: 72×72
F: 96×48 (Vertical type)
G: 48×48 (Horizontal type)
- High and low temperature control, Timer Startup by a short current and display counting down
- Timer Startup with set temperature and Counting down
- Turn switch on to start timer and the relay will be closed. When the timer reaches the preset value, the relay will be opened.
- Release switch to start timing, display will show remaining time, when the timer reaches the preset value, the relay will be closed.
- Releasing switch to start timing, the relay will be closed, when the time reaches the preset value, the relay will be opened.
- Output Type
Omit: Relay Output
V: Logic Output (for the control of solid-state relay SSR)
G: SRC (under 300W only)
WG: external silicon controlled rectifier
WR: external relay
- Thermocouples types:
K: 0-800°C; E: 0-600°C
- LRL
- URL
- Control Mode
0: On-Off Control
4: On-Off PID Control (heating Type)
- Timing Output
0: no timing output
1: Relay Output
2: Buzzer Output (internal)
3: Buzzer Output (external)
- Timer Mode
0: NO timing
1: Timer Startup by a switch and display counting down

II. Installation

2.1 Caution when installing

- Please install the controller under the following conditions:
- Temperature: 0 to 50 degrees C.
 - Humidity: 45% to 85% RH.
 - Atmospheric pressure: 86 to 106kPa
- Please avoid the following conditions during installation:
- Rapid temperature changes, leading to dew condensation.
 - Corrosive gases (especially sulfide gas, ammonia, etc.) or flammable gases.
 - Direct vibration or shock
 - Contact with water, oil, chemicals, steam, smoke, or hot water
 - High concentrations of atmospheric dust, salt or iron particles
 - Large inductive interference, resulting in static electricity, magnetic fields or noise.
 - Direct sunlight.
 - Radiant heat sources, etc

IV. Operation

4.1 The order of calling out the various functions

• After the instrument is power on, the upper row displays InP and the lower row displays the calibration mark of the sensor to express the input type. 4 seconds later, the upper row displays the upper limit of the measuring range and the lower row displays the lower limit of the measuring range then the measurement range is determined. Again after 4 seconds, the upper row displays the measuring value and the lower row displays the setting value. And then the system enters its normal working state.

• Setting of the temperature: Push the key X, the upper row displays the value of SP and push \blacktriangle or \blacktriangleright key to make the lower row display its needed value. And push the \curvearrowright key to promote the system to the ST setting mode.

• Setting of Timing: The upper row displays ST and push \blacktriangle or \blacktriangleright key to make the lower row display the needed value. Again push the \curvearrowright key to promote the system return to its standard mode.

• Setting of the control parameters: Push the \curvearrowright key above 4 seconds, the upper row shows the prompt code of the parameter (detail can see the schedule table of the control parameters) and then push \blacktriangle or \blacktriangleright key to make the lower row display its needed value. Continue push the \curvearrowright key can make the upper row display the prompt code of each of another parameter in turn. Again push \blacktriangle or \blacktriangleright Key to update the value of parameter to its needed value, and again push the X key above 4 seconds, the system returns back to its standard mode. (If no key has pushed down, after 1 minute the system will come to its standard mode).

• If under the red display the “ooo” is appeared, the thermocouple is in reverse connection, else above the red display the “ooo” is appeared, the thermocouple is in open current or the measuring temperature exceeds the measurement range.

• The Auto-tuning function of the instrument's parameters: After 20 seconds of pushing down the \blacktriangle key, the AT indicator is twinkle and the controller begins to start its Auto-tuning. The temperature goes through one to two times of oscillation and the AT indicator extinguishes. The instrument will control the process with the updated parameters, which will be permanently persevered.

• The switch function of Celsius and Fahrenheit temperature: Hold down the key \blacktriangle or \blacktriangleright simultaneously, the upper row shows LK, again push the X key to prompt the upper row appears Sn and lower row appears K-C (Celsius temperature) or K-F (Fahrenheit temperature) and push \blacktriangle or \blacktriangleright key to carry out the transform of the scale of temperature.

• Selection of the measurement range: Hold down the key \blacktriangle or \blacktriangleright simultaneously, the upper row shows LK, again push the X key to prompt the upper row appears rL and lower row appears 0, and again push X key to make the upper row appear rH, at that time the lower row appears the needed measurement range.

Address: 128 Zhenyuan Road, Shanghai, China
 Tel: +8621-66186368 (Chinese) +8621-66186386 (English)
 Fax: +8621-66186226 Email: yatai@yatai.sh.cn
 Website: http://www.yatai.sh.cn
 Technical Support: +862136160962 (Chinese)

Shanghai Yatai Instrumentation Co., Ltd.

4.2 The schedule table of the control parameter

Prompt Symbol	Name	Setting Range	Illustration	Beginning Value
HLI	Setting of Alarm	-199~Range C	Setting of Alarm 1. Inensitive interval of alarm is equal to a constant value 0.4. (This value is meaningless)	50 or 50.0
AL1	Proportional band (Heating Side)	0~400 C	Proportional Control: The more the value of P, the less the proportional action and the less the system gain; only acting on the heating side. (P=0 is ON/OFF Control)	30
P	Integral Time	0~990 Seconds	Integral Time: The more the value of I, the less the integral action I=0 is PD Control. AI= (Remained ErrorP)×100	240
I	Differential Time	0~990 Seconds	Differential time: The more the Value of D, the more the differential action, which is able to overcome overshoot (D=0 is PI Control)	60
d	Overshoot restrain (Proportion re-setting) (Inensitive interval of ON/OFF Control)	0~100%	Used to restrain Overshoot (AR is set to 1.5~2 times of the output empty ratio in the steady state of the system)	100
AR	Control period (Heating Side)	1~100 Seconds	Reduce Ar energy and temperature overshoot, when SP is changing. Ar must be adjusted; Ar must be confirmed and will be set according to SP value automatic	20
Ar	Offset of the Process Value	-198~998 C	When the relay output \pm 20% SSR and Si-controlled switch transwitch \pm 2s, continuous output T is equal to Is, only acting on heating side	0
f	Times Control Mode	0~16	Using for correct the measurement error caused by the sensor and the compensate line of the thermocouple	0
T			0 or 10, when switch is on, display will start counting down to 0. When the relay is closed, the alarm will be turned on until the switch is off and the relay is open. The alarm shall stop to complete one cycle of operation. 0 or 1: When switch is on, display will start counting down to 0 as relay is closed. When the relay is open, display will start counting down to 0. The alarm shall stop to complete one cycle of operation. 2 or 12: High and low temperature control. Output will be set when the temperature is below the preset value. Output will be reset when the high temperature preset value, output will be set. When the high temperature preset value is reached, output will be reset and the counting down will start. 3 or 13: Switch on to start counting down. The relay is closed or the alarm is on when remaining time is 0 until it has been switch off and on again. Once switch is cycled, the relay will be opened and the alarm will be stopped to complete one cycle of operation. 4 or 14: Switch on to start counting down and the relay will be closed. When remaining time is 0, the relay will be opened or the alarm will be turned on. Cycle of operation will be completed until the next release of the switch to start, the relay will be closed or the alarm will be turned on. The relay will open or the alarm will be closed or the alarm will be turned on. When remaining time is 0, the relay is open and one cycle of operation is completed until the next release of the switch to start, the relay will be closed and the alarm will be stopped. Others: not applicable; Note: when the digit segment of 10s is one, mute the device by press any key.	0
Run			000: All parameters can be updated 001: Only the Set Point Value can be updated 002: All parameters cannot be updated.	0
LCK	coded lock	000, 001, 002		
LCK				

Notice: Change of each function parameter in the table may alter the control effect of the system.

V. Service and Maintenance

• This controller is under warranty for 12 months since the day of purchase (the warranty only stands if the problem is caused by the malfunction due to manufacturing). Any repairment for damages caused by improper use of the controller will be charged. The controller is provided with lifetime maintenance and repair on cost.

• Please keep the controller in a dry place with air and NO corrosive gas.